

Whole House Air Purification

The PROIAQ-AZ In-Duct Air Purifier works around the clock to transform ambient air and humidity into safe, trace levels of hydrogen peroxide. This process continuously reduces viruses, bacteria, mold, and odors, in the air and on surfaces.

With the PROIAQ-AZ In-Duct Air Purifier, you get consistent results with trusted technology, lab-tested pathogen reduction, and disinfection.



FEATURES/BENEFITS

Whole-Home HVAC Integration	Installs directly in horizontal, upflow, or downflow systems to purify your home.
UV Multi-Spectrum Light	Removes odors, VOCs and airborne contaminants and generates safe, low level hydrogen peroxide.
Low-Maintenance	Long-life lamp (2 years) with a clear light indicator for lamp replacement reminder.

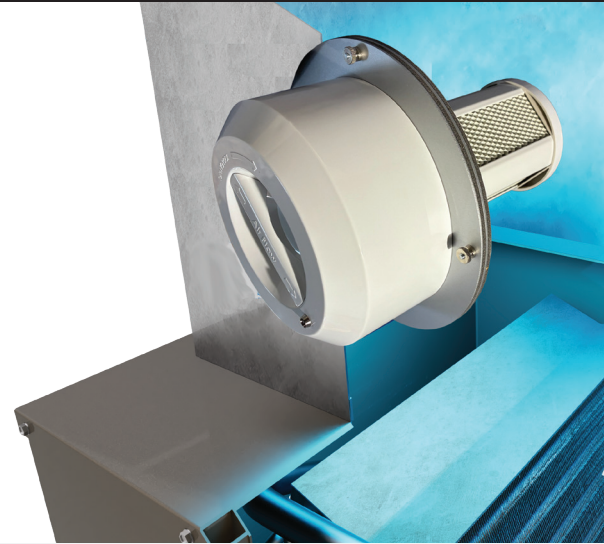

CLEAN AIR



In-Duct Air Purification System Helps Neutralize Mold, Bacteria, Viruses, and Allergens

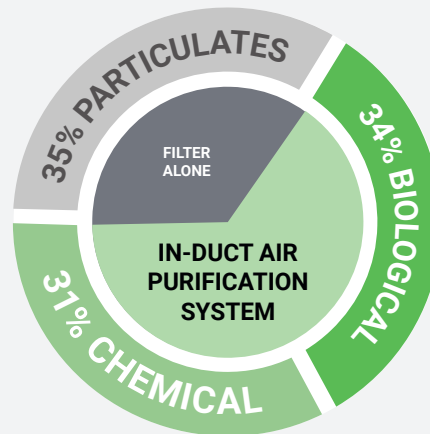

CLEANER AIR BEYOND FILTRATION

Standard filters capture only particulates (about 35% of indoor contaminants). Our **In-Duct Air Purification System** also tackles the other two-thirds:

Biological: Bacteria, viruses, mold, allergens (34%)

Chemical: Odors & VOCs from smoke, pets, cooking, carpets, cleaning products, fuels (31%)

Independent lab testing has shown that our NC2I technology substantially reduces bacteria and viral pathogens, including:

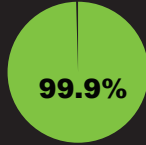

- SARS-CoV-2
- Pseudomonas Aeruginosa
- Candida Auris (Fungi)
- Listeria

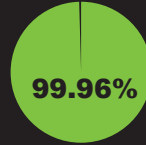

- MRSA

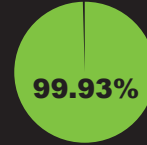

- HIN1 Influenza
- MS2 Bacteriophage

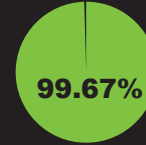

- E. Coli



- Clostridium Difficile Colitis (Spores)

SPECS

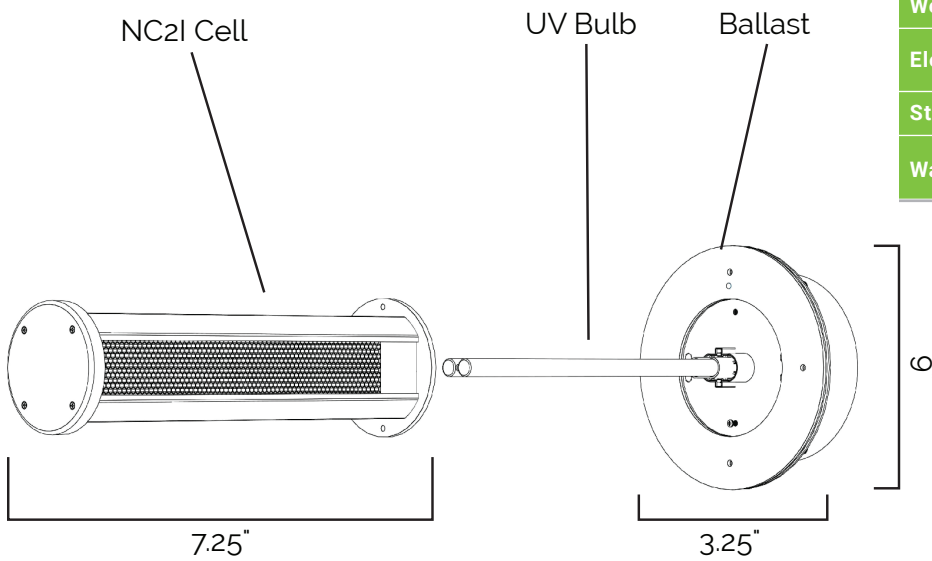

PROIAQ-AZ In-Duct Air Purification System Specs / Commercial Grade	
Coverage	Up to 5,000 sq ft
Size (HxWxD)	9" x 9" x 10.5"
Weight	3.5 lb
Electrical	110 VAC plug can be wired 110-277 VAC per ETL/UL listing
Start-up	35W
Warranty	Lifetime for all parts except lamp (2 yr lamp warranty)

